

> We are DEVELON

We trace our roots to 1937 as one of Korea's first large scale machine plant. Throughout time we have consistently delivered exceptional products and solutions.

DEVELON is a bold name that reflects our core ambition to continue developing onwards and leaving behind a positive footprint in our world. Moving forward, we seek to be part of our customers and partners' endeavor to build a better world.

Powered by **Innovation**



©2024 HD Hyundai Infracore. All rights reserved.
HDIPBE-01-2402

develon-ce.com

Certain specification(s) are based on engineering calculations and are not actual measurements. Specification(s) are provided for comparison purposes only and are subject to change without notice. Specification(s) for your individual Develon equipment will vary based on normal variations in design, manufacturing, operating conditions, and other factors. Pictures of Develon units may show other than standard equipment.

DEVELON

Wheel loader

DL280-7M

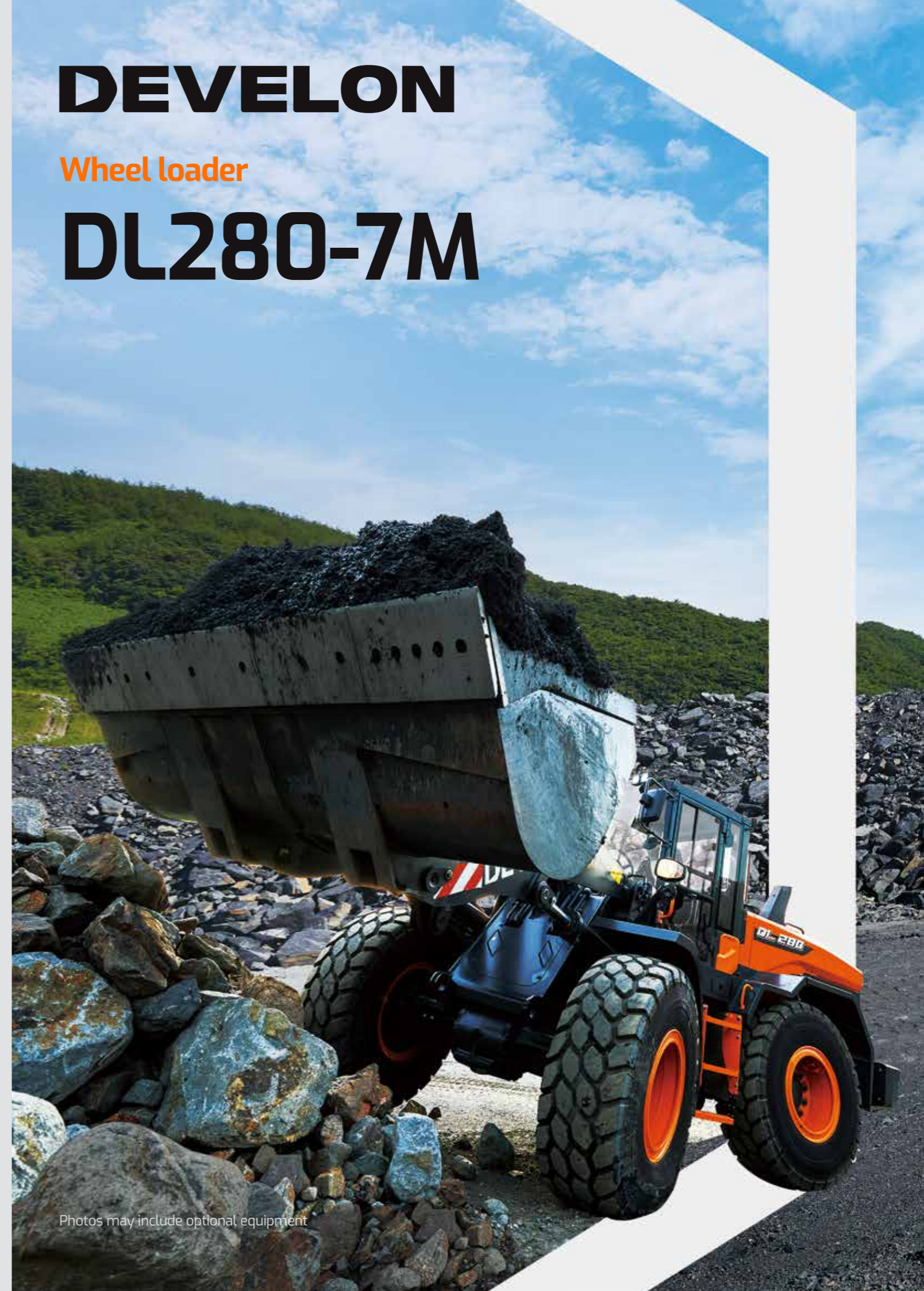

Photos may include optional equipment

PERFORMANCE WITH BOLD POWER

DL280-7M

Take Active Steps for More Possibilities

The next generation supernova had just occurred to make your business even better. Unmistakable performance with bequeathed gene of predecessor's functionality and power. Right combination of superb engine power and progressive dynamics make compelling story of its assertive nature and progressing spirit. DL280-7M is ready to fit your need, bearing every capability and durability for everyday uses to most challenging works.



A SUPERB CAPABILITY

Dominant engine power and peerless tipping load. Impressive breakout force and high traction make penetration easy and allow you to handle the hardest materials. Athletic balance of powerful hydraulic system and controllability makes work quick and efficient.

UNCOMPROMISING QUALITY AND DURABILITY

DL280-7M's superior quality and durability make it an equipment you can count on. Most updated form was applied, which has been proved and verified in diverse market.

BRIGHTLY CHANGED IN AND OUT STYLING

DL280-7M offers features which meet both emotional and technical needs for operator. To procure intuitive command center for a performance, all machine interfaces are ergonomically positioned within easy reach. Its bold in-and-out design delivers you comfort and total control.

WE ARE BACK WITH NEW FEATURES

All the Nice Features of Previous Model
Bodily Succeeded, Even Nicer Things to Come

CABIN VISIBILITY

Improved visibility to the left and right bottom section of the front windshield for easy positioning of front wheels.

ENHANCED COUNTERWEIGHT

Reinforced standard counterweight with additional counterweight option.

INCREASED OPERATOR COMFORT

The new spacious cab offers an operator-friendly environment with top-class all-round visibility. It centers around a high comfortable seat.

LS HYDRAULIC SYSTEM

Load sensing hydraulic system produces flow and pressure for the implement system only when needed, improving machine productivity and resulting in lower fuel consumption.

DEVELON FLEET MANAGEMENT (OPTIONAL)

Offering 'preventive maintenance service' based on machine operating data. Providing an expert level consultation to dealers. Functioning as fleet management tool for the customers.

NEW CLUSTER AND NEW KEYPAD

Intuitive gauge panel and keypad enable easy access to machine settings and maintenance data. All switches and operating mechanism integrated to improve operational convenience.

AUTOMATIC REVERSE FAN

Reversible functionality of the fan, which blows air in the opposite direction, allows self-cleaning of the cooling units.

ENHANCED LIS (LOAD ISOLATION SYSTEM) (OPTIONAL)

LIS Absorbs the impact on the lifting arm, cutting off the shock not to be transferred to cabin and body. Enhancing the balance, productivity and operator comfort.

NEW 8-INCH MONITOR FOR REAR-VIEW CAMERA (OPTIONAL)

Large and bright LCD monitor to view rear surroundings for safe operation. Wide angle Rear-view camera integrated into the radiator grill, offering seamless design and protection.

LSD (LIMITED SLIP DIFFERENTIAL)

Stability and mobility also reinforced further by LSD (Limited-Slip Differentials) lock, being applied as a standard equipment.



EXPERT IN EVERY FIELD

DL280-7M is a Complete Solution for Every Work

DL280-7M is undoubtedly one of Develon's most versatile equipment, which is designed for all-round performance. Superior breakout force makes penetration easy and allows you to handle the hardest materials. Dominant tipping load with the perfect balance of maneuverability ensures you to handle any picky environment. All of which give optimum capability to DL280-7M's ground-breaking performance.

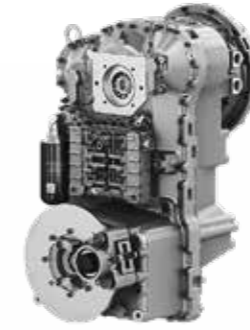

FULL AUTO TRANSMISSION

The electronic powershift transmission is particularly smooth. Gear ratios perfectly spaced to give optimal speed. Giving comfort and delivering excellent traction in every working condition. Built-in electronic controls enhanced productivity and durability. Transmission has three modes of operation, 'Manual', 'Automatic' and 'Semi-Automatic'. 'Automatic' mode provides self-regulative shift for all gears and 'Semi-Automatic' mode provides automatic option after the first acceleration and gear shift.

DEVELON ENGINE (DL06)

DL280-7M gives high performance through in-house engine. High power of engine output of 140 kW and impressive torque range enables to precisely deliver the power. Wholly delivered engine power which is perfectly harmonized with hydraulic system provides stable working speed and maximum productivity and profitability.





LIMITED SLIP ZF DIFFERENTIAL

The front and rear axles are fitted with limited-slip differentials as standard. This automatically ensures the maximum tractive effort and easy driving over soft and swampy ground. It also reduces the risk of skidding and prevents excessive tire wear. Also ensures low fuel consumption and high travel speeds in load and carry.



IMPROVED LIS (LOAD ISOLATION SYSTEM)

In loaded traveling, the impact on the front could be transferred to the body, may give rise to equipment damage and driver uncomfortableness. LIS option absorbs tremor and minimizes swaying movement of lifting arm while the equipment carries the load. Ultimately enhancing the durability of front structure and operator's comfort.

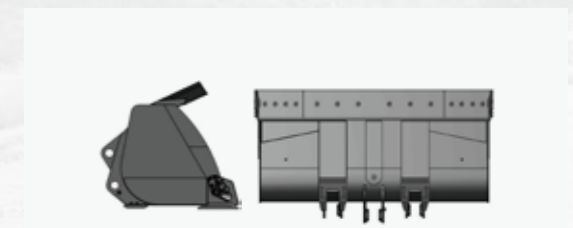

AGGREGATE BUCKET OPTION

Designed rehandling bucket lines to give faster and more efficient bucket fill. Fortified bucket options provided for handling aggregate material.

IMMORTAL DURABILITY

Endless Possibilities, Reliability and Durability Equipped in Standard

With you for the long run. Powerful, poise and durable DL280-7M is here to support you with purposeful design and endless possibilities. Robust structural elements were used of give credence to DL280-7M's capabilities. Ensuring long life and high uptime even in extreme sites.

Countless engineering and tests have been done for optimized high performance. DL280-7M is a robust equipment that is optimally prepared for use for almost any construction challenge.



*Photos may include optional equipment.



1. ENHANCED TRANSMISSION DAMPER

Enhanced performance of transmission damper. Quality improvement in both equipment serves low noise and vibration level, during travelling.



2. RADIATOR GRILLE WITH STEEL STRUCTURE

The radiator grille with its aerodynamic steel structure increases air flow which facilitates cooling and the maintenance process.



3. PROPELLER SHAFT

A protective cover has been installed to protect the oil seal from dust, foreign objects and premature wear. Robust steel suspension provides excellent transmission of power and ensures reliable stability.

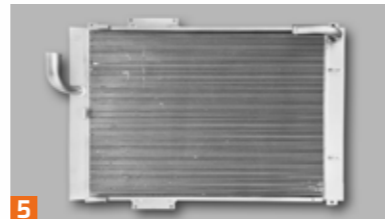

5. LARGE CAPACITY TRANSMISSION OIL COOLER

The large capacity transmission oil cooler ensures durable and stable operation of transmission.



4. IMPROVED ENGINE DURABILITY BY TECHNOLOGICAL IMPLEMENT

Water separator in fuel to prevent engine damage. Large capacity forced air cleaner removes over 99% of airborne particles, reducing the risk of engine contamination and lengthen the cartridge change intervals.



6. ORFS-ALL PORTS

To ensure perfect oil tightness, all ports, are fitted with ORFS type. Even in the low pressure ports such as pilot line and pressure line are ORFS type.



7. REMOTE AXLE BREATHER

Increased the length of front axle breather for prevention of pollution from particle matter. Added additional remote type axle breather on rear axle.



8. RADIATORS MOUNTED ON RUBBER MOUNTS

The radiators are mounted on rubber mounts to effectively with stand vibrations.

9. APPLIED MORE RIGOROUS QUALITY STANDARD

All key components meet the increased new quality standard. Applying Develon single platform, which verified in advanced market.

10. DRIVE SHAFT

The dust seal has been fitted to protect exterior pollution for wear resistance. The air ventilation relief valve is also installed against over-filling.





THE ROOM OF PROGRESS

Intuitive, Practical and Capable Cabin but With Refined Comfort

Heighten your sensory at DL280-7M's wholly changed seat of progress. A space of refinement, with authentic features, meticulously chosen. Completely re-designed cabin interior is fitted with climate control systems and air suspension seat. Astute use of space and clever storage solutions gives uncluttered environment and even greater comfort than before.

The cabin is fitted with enhanced view of the field ahead and including some of the most advanced safety features. With functions and operating information minimized into intuitive gauge panel.

SPACIOUS CABIN COMFORT

Refined interior with enhanced legroom and extendable storage space guarantees a serene ride to you. A more orderly interior equipped with high-class designed upholstery and thoroughly changed comfort accessories. This ensures operator to have a clear and uncluttered workplace at all times.



1



2



3



4



5



6



7

1. ALL AROUND VISIBILITY

Enlarged front windshield assures best possible all-around visibility. Panoramic cabin windows and suitable seat position assists on safety and controllability promotion via enhanced lower part of visibility on side position. In crowded city streets or in hazardous construction workplace, operator can get better control and command of surroundings.

2. SMALL DETAILS ADD THE FEELING OF REFINEMENT

Operationally re-designed brake pedal and non-slip floor mat equipped. Heating and ventilation, Air conditioning system upgraded for pleasant environment. USB charger and sunglass case is also equipped for additional comfort. Rear sun visor is also equipped for UV protection.

3. AIR CONDITIONING

The high performance of air conditioning system provides an air flow which is adjusted and electronically controlled according to the conditions. A double air filter protects the operator's environment.

4. NEW 8-INCH MONITOR FOR REAR-VIEW CAMERA (OPTIONAL)

Large and bright LCD monitor to view rear surroundings for safe operation. Wide angle rear-view camera integrated into the radiator grill, offering seamless design and protection.

5. STEERING COLUMN AND THUMBWHEEL JOYSTICK

Joystick enables united and intuitive control of your wheel loader. The steering column features both tilting and telescopic functions.

6. ERGONOMICALLY DESIGNED WORK PEDAL

Ergonomically designed work pedals placed at both ends. Pedal angle adjusted to relieve the pressure on ankle and joints, reducing fatigue and to lessen the load of operator.

7. CENTRAL GAUGE PANEL

A new gauge panel put essential information right in front of the driver. The compact central monitor clearly shows the perfect overview of the machine status and warning messages at a single glance.

- 
1. All Around Visibility
 2. Small Details Add the Feeling of Refinement
 3. Air Conditioning
 4. Rear View Monitor (Optional)
 5. Steering Column
 6. Ergonomically Designed Work Pedal
 7. Central Gauge Panel

EASY MAINTENANCE

Keep Working With Smart Maintenance Procedure

DL280-7M facilitates features for machine to operate in best condition at long intervals by ensuring short and easy maintenance procedure. With helpful features including grouped filters and greasing points. Multiple handrails and platforms offered for safe maintenance access.

Thoroughly concentrate on your main work. DL280-7M is intelligent enough to take care of itself. Automatic reversible fan which is tolerant for various harsh region allows self-cleaning of the cooling units and lengthen the change intervals.

AUTOMATIC REVERSE FAN

Tolerant for a range of conditions including dusty, sturdy, harsh environments. Electronically controlled cooling fan regulates the temperature of the vital components. The optional reversible functionality of the fan, which blows air in the opposite direction, allows self-cleaning of the cooling units. Reducing the risk of contamination and lengthen the change intervals.

AIR INTAKE

Maintenance-free cyclone air pre-filter separates more than 99% of particles 20 microns in size and larger. Cleaning and cartridge replacement are only needed at long intervals. Extending the air filter's lifetime, the pre-filter also ensures better combustion and a longer engine lifetime.

SAFE ACCESS

To facilitate access and mobility on the machine, multiple platforms and handrails ensure that the operator always has a firm support to hold on to and 3-point contacts.





SINGLE LAYER COOLING MODULE RADIATOR
Applied Single layer cooling module structure.
Simple structure made easy for cleaning.



TRIPLE-ELEMENT AIR FILTER
The forced-air cleaner removes 99% of particles and is backed up by a turbo pre-filter. Cleaning and cartridge replacement are only needed at long intervals.





1. TRANSMISSION FILTER

Transmission filters located in easy reach. Like the rest of the machine's service components, can be checked from ground level.

2. ADDITIONAL WATER SEPARATOR

Additional water separator comes standard to allow the engine to perform at its' top condition regardless of fuel quality.

3. REMOTE GREASING LUBRICATION PORTS

Front pins can be lubricated from the outside of the machine. Enable to skip the unnecessary procedure of struggling to reach the unapproachable lubrication ports, including crawling under the machine.

4. DEVELON FLEET MANAGEMENT

Upgraded Develon Fleet Management provides fuel consumption data, error code, parts replacement interval information. Via Develon Fleet Management service, you can always monitor the operating data, anytime or anywhere. Optimized for routinely check to prevent machine troubles and down time.



DEVELON FLEET MANAGEMENT

Telematics Service (OPTIONAL)

TELECOMMUNICATIONS Data flow from machine to web



TELEMATICS TERMINAL

Terminal device is installed and connected to a machine to get machine data.

TELECOMMUNICATION

DEVELON provides Dual mode (Cellular, Satellite) communication to maximize communication coverage

DEVELON FM WEB

User can monitor machine status from DEVELON FM Web

TELEMATICS SERVICE BENEFITS Develon and dealer support customers to improve work efficiency with timely and responsive services

CUSTOMER

Improve work efficiency

- Timely and preventive service
- Improve operator's skills by comparing work pattern
- Manage fleet more effectively

DEALER

Better service for customers

- Provide better quality of service
- Maintain machine value
- Better understanding of market needs

DEVELON

Responsive to customer's voice

- Utilize quality-related field data
- Apply customer's usage profile to developing new machine

FUNCTIONS (WEB/APP) Develon Telematics Service provides various functions to support your great performance

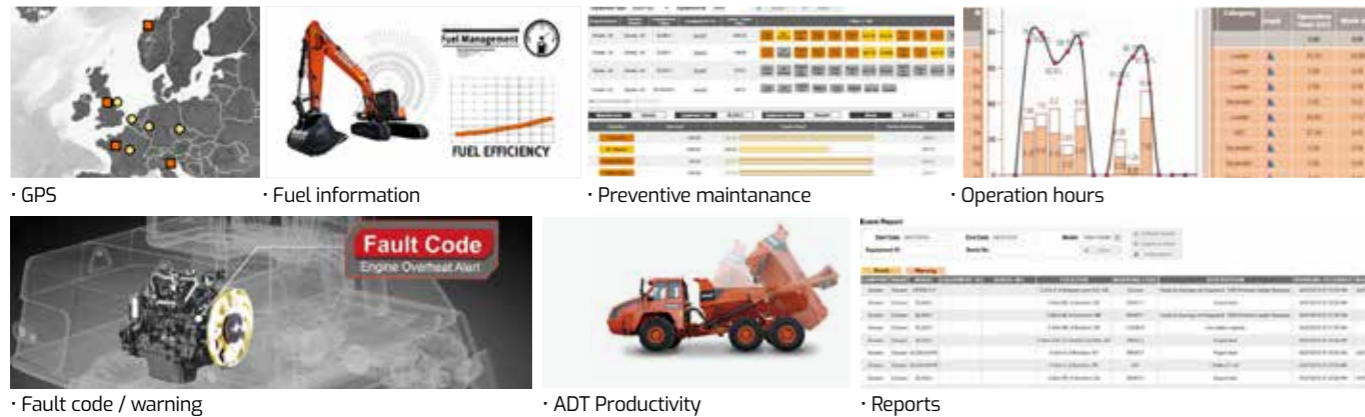

FUNCTION	EXCAVATOR	WHEEL LOADER	ADT
GPS	All models	All models	All models
Operation hours	All models	All models	All models
Maintenance parts	All models	All models	All models
Fault code / Warning	All models	All models	All models
Fuel information	All models	All models	All models
Dump capacity	N/A	N/A	All models

GLOBAL PARTS NETWORK

QUALITY-PROVEN MAIN COMPONENTS

Develon provides fast and precise worldwide delivery of genuine Develon parts through its global PDC (parts distribution center) network.



GLOBAL NETWORK

The global network of the GPDC (Global Parts Distribution Center) maximizes its fill rate by making sure that each center is stockpiled with all the critical parts required for businesses in its area. The network also minimizes the time and costs required for parts delivery by positioning PDCs close to major markets around the world. Develon PDCs communicate with customers in their time zone, informing them that they are open for operation, and deliver parts to them as early as possible.

THE GLOBAL PARTS DISTRIBUTION CENTER NETWORK

PDCs had been set up as shown below, including Mother PDC in Ansan, Korea. The ten other PDCs include one in China (Yantai), three in USA (Atlanta, Seattle and Miami), two in Europe (Germany and the UK), one in the Middle East (Dubai), two in Asia (Singapore and Indonesia) and one in Brazil (São Paulo).

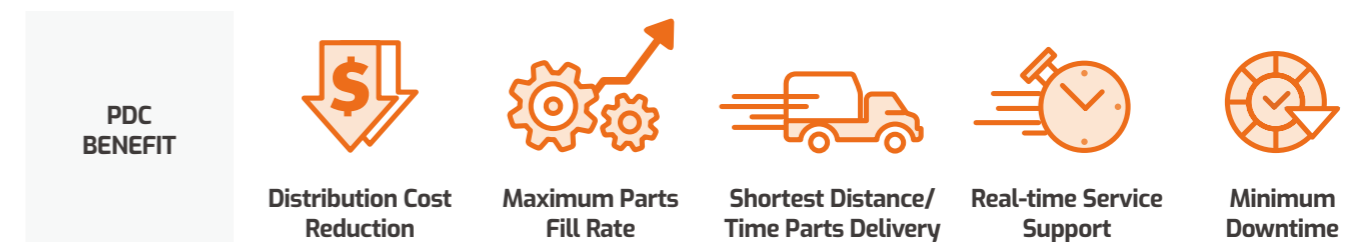

ATTACHMENTS

Aggregate bucket is the most commonly used bucket in the construction equipment market and is designed mainly for use in heavy construction but also used in low density mining and quarry application.

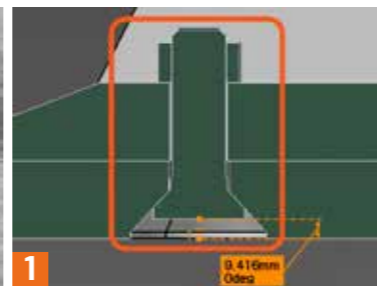
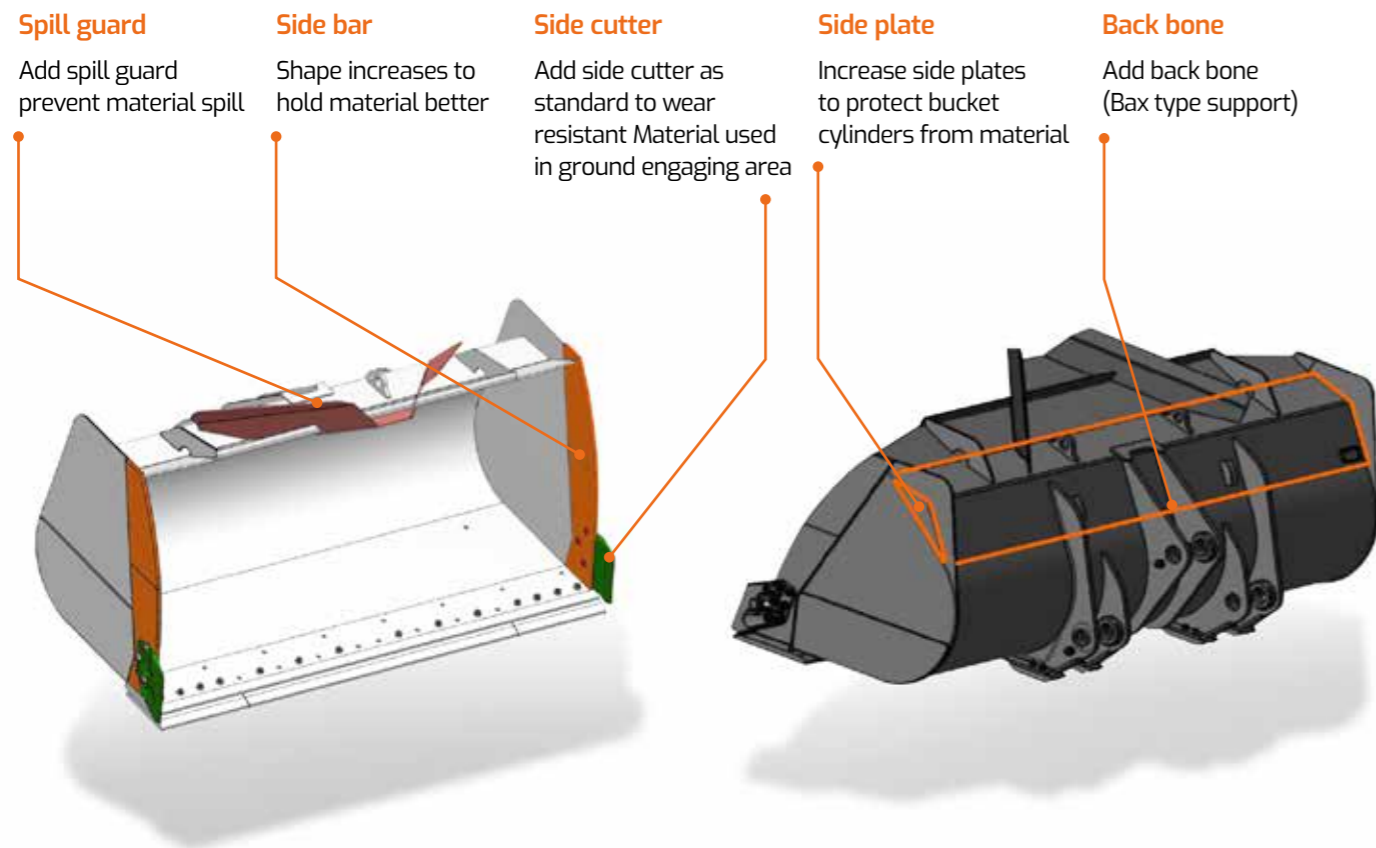

1
PLOW BOLT FOR CHANGEABLE PARTS
New plow bolt will be applied on tooth adaptor and cutting edge



2
CHANGEABLE BOTTOM PLATES
Operator can change wear plate easily



QUICK COUPLER

	DLQC28
WEIGHT (kg)	530



PALLET FORK

	DLPF28
WEIGHT (kg)	1,050
LENGTH (inch)	60
OPERATING WIDTH (mm)	600 ~ 2,160



LIFTING ARM

	DLLA28
WEIGHT (kg)	610
LOAD (kg) (REACH (m))	3,000(3.5) / 2,000(4.6) / 1,400(5.8)



General Purpose

General purpose grapples is an all-round grapple for handling and sorting entire trees or for grabbing single stem.



Tropical

tropical timber grapples are very wide with two separate clamping arms to hold large, heavy items securely, principally intended for handling large diameter and high density tropical type timbers.



Sorting

sorting type grapple has relatively long and straight tines so the grapple can be easily filled when loading from stacks or sorting bunkers. Both the Unloading and the sorting grapple can be fitted with a hydraulic heel/kick out.

LOG GRAPPLE

	General Purpose	Tropical	Sorting
WEIGHT (kg)	1,700	1,850	1,700
LOG DIA. Ø (mm)	320	1,000	1,300

TECHNICAL SPECIFICATION

ENGINE

The high performance Develon DL06 6 cylinder, direct injection, turbo charged, air-air intercooler engine offers low fuel consumption and low exhaust emissions.

Rated Power

140 kW @ 2,100 rpm (SAE J1995, gross)

Max Torque

785 N.m @ 1,500 rpm

Displacement

5,890 cc

Bore x stroke

Ø 100 x 125 mm

Battery

System voltage : 24 V

Quantity : 12 V x 2

Capacity (AMP) : 100 Ah

Starter power

24 V / 6 kW

Alternator output

24 V / 80 A

AXLES

The front and rear axles with planetary hub reductions are built on the base of very reputed components. Fitted as standard, the front and rear limited slip differentials, ensure the traction is optimal in all circumstances.

Type

Fully floating planetary-type

Limited slip Differential (front and rear)

30 %

Brake

Dual circuit multi-plate wet discs. Hydraulic actuation with pump and accumulator. A spring applied and hydraulically released parking brake is mounted on the transmission shaft.

TRANSMISSION

"Full Power Shift" transmission. It can be used in manual or automatic modes. This transmission is based on components having excellent worldwide reputations. It is equipped with a modulation system allowing soft gear shifting and inversion of travel direction. Safety devices also protect the transmission of bad operations. The gear and direction shifting is operated by a single lever to the left of the steering wheel. A travel direction control is also mounted on the hydraulic joystick. (Optional) The transmission can be de-clutched by the operation of brake pedal to increase the power available to the hydraulic pumps. A safety device prevents the starting of the engine when not in neutral.

Torque converter

Stall ratio : 3.009

Travel speed (km/h)

Forward : 6.1 / 12.2 / 22.9 / 35.3 (1/2/3/4)
Reverse : 6.5 / 12.9 / 24.0 (1/2/3)

HYDRAULIC SYSTEM

The hydraulic system uses variable displacement axial piston pump.

Pilot actuation with standard single lever.

Automatic arm kick-out is standard.

All of hydraulic lines are equipped with special seals (ORFS)

Max flow rate

246 L/min AT 2,000 rpm

Working Pressure

265 bars

OPERATOR'S CABIN

The modular cabin allows excellent visibility in all directions. The optimal ventilation is obtained by numerous ventilation outlets. Touch buttons control the air re-circulation air conditioning and heating systems. The air of the cabin is filtered.

All necessary information for the operator are centralized in front of operators.

The main functions are actuated via switches located on a console at the right of the operator.

Generous storage places are well located. The cabin, mounted on viscous element and equipped with an air suspended seat, offers a better comfort for the operator.

Access door : 1

Emergency exits : 2

The cab conforms ROPS ISO 3471 and FOPS : ISO 3449

Guaranteed external noise level Lwa
(following ISO 6395) 103 dB(A)

Guaranteed inside of cabin noise level Lpa
(following ISO 6396) 76 dB(A)

STEERING

The steering system is a load sensing type with a flow amplifier and a priority valve.

Steering angle

40°

Emergency steering system with hydraulic pump driven by electric motor. (Optional)

LIFTING SYSTEM

The lifting system with two cylinders and Z configuration is designed for the toughest jobs. The breakout force is very important and the bucket movements are fast. The bucket angles are well kept in good positions on all the range of bucket movement.

Lifting cylinders (2)

bore x stroke : 135 x 790 mm

Bucket cylinders (1)

bore x stroke : 160 x 510 mm

MAINTENANCE

Maintenance is easy due to excellent access. The radiator fan swivels to aid cleaning. The transmission is electronically controlled. An error coding system allows easy diagnosis of the systems and proper intervention

Engine (oil) - 24.5 L
Radiator (cooling liquid) - 34 L
Fuel - 235 L
Hydraulic oil - 120 L - ST
Transmission oil - 37 L
Front axle - 35 L
Rear axle - 35 L

GENERAL SPECIFICATION

ITEMS	UNIT	STD	FULL OPT
OPERATING WEIGHT	kg	15,104	16,560
ENGINE (SAE J1995 GROSS) (SAE J1349 NET)	RATED POWER (GROSS)	kw/rpm	140/2,100
	RATED POWER (NET)	kw/rpm	140/2,100
	MAX. POWER (GROSS)	kw/rpm	140/2,100
	MAX. TORQUE (GROSS)	kw/rpm	785/1,500
SYSTEM PRESSURE (FRONT/STEER)	bar	265/195	
TRAVEL SPEED (4 SPEED)	FORWARD (1/2/3/4)	km/h	6.1/12.2/22.9/35.3
	REVERSE (1/2/3)	km/h	6.5/12.9/24.0
FRONT SPEED (RAISE/DUMP/DOWN)	sec	5.4/1.5/3.5	
GRADEABILITY	%(°)	58(30)	
TIRE SIZE	-	20.5R25(L3)	
BREAKOUT FORCE	kN	146	136
MAX. STEERING ANGLE	deg	40°	
TURNING RADIUS (TIRE EDGE/ COUNTERWEIGHT EDGE)	mm	5,510 / 5,470	

ITEMS	UNIT	STD	FULL OPT	
WORKING RANGE	BUCKET CAPACITY (SAE HEAPED)	m ³	2.7 GP BOT	2.8 GP BOC
	DUMP HEIGHT AT 45°	mm	2,740	2,820
	DUMP REACH AT 45°	mm	1,230	1,160
	MAX. DUMP ANGLE (FULLY RAISED)	deg	46°	
	MAX. TILT ANGLE (ON GROUND)	deg	43°	
	MAX. TILT ANGLE (FULLY RAISED)	deg	61°	
	MAX. TILT ANGLE (AT CARRY)	deg	49°	
	BUCKET HINGE HEIGHT	mm	3,935	
	DIGGING DEPTH (0° LEVEL)	mm	120	115
	TRAVEL DIMENSION	OVERALL LENGTH	mm	7,760
OVERALL WIDTH (BUCKET)		mm	2,740	
OVERALL HEIGHT		mm	3,360	
GROUND CLEARANCE		mm	400	
WHEEL BASE		mm	3,050	
TREAD		mm	2,040	
SOUND LEVEL (MEASURED / GUARANTEED)		IN CAB (ISO 6396)	dB(A)	75/76
	EXTERNAL (ISO 6395)	dB(A)	102/103	
FUEL TANK CAPACITY	Liter	235		
FUEL CAPACITY	Liter	30		

OPERATIONAL DATA

LOADER TYPE		General purpose (Z-BAR)		High Lift (Z-BAR)	
		STD			
BUCKET MOUNT		PIN ON	PIN ON	PIN ON	PIN ON
Configuration	Unit	Teeth	Bolt-on edge	Teeth	Bolt-on edge
Capacity heaped ISO/SAE	m ³	2.7	2.8	2.7	2.8
Tooth type		General Purpose	General Purpose	General Purpose	General Purpose
Bucket width	B mm	2,740	2,740	2,740	2,740
Breakout force	kN	146	136	138	128
Static tipping load (straight)	kg	12,046	11,821	9,873	9,675
Static tipping load (at full turn)	kg	10,618	10,420	8,703	8,528
Dump height (at 45°) (at fully raised) 1)	H mm	2,740	2,820	3,200	3,280
Dump reach (at 45°) (at fully raised) 1)	I mm	1,230	1,160	1,195	1,125
Dump height (at max. dump) (at max. reach) 1)	mm	590	690	585	685
Dump reach (at max. dump) (at max. reach) 1)	mm	1,565	1,530	1,860	1,825
Digging depth	mm	120	115	209	203
Height at bucket pivot point	J mm	3,935	3,935	4,395	4,395
Max. tilt angle at carry position	deg	49	49	48	48
Max. tilt angle at fully raised	deg	61	61	58	58
Max. tilt angle on ground	deg	43	43	40	40
Max. tilt angle at max. reach	deg	61	61	58	58
Max. dump angle at max. reach	deg	67	67	68	68
Max. dump angle on ground	deg	67	67	77	77
Max. dump angle at fully raised	L deg	46	46	45	45
External radius at tire side	O mm	5,510	5,510	5,510	5,510
External radius at bucket edge	Q mm	6,145	6,115	6,370	6,335
Wheel base	E mm	3,050	3,050	3,050	3,050
Width at tyres	mm	2,640	2,640	2,640	2,640
Tread	F mm	2,040	2,040	2,040	2,040
Ground clearance	G mm	400	400	400	400
Ground Clearance at osc.	T mm	389	389	389	389
Overall length	A mm	7,760	7,655	8,180	8,075
Overall height	C mm	3,360	3,360	3,360	3,360
Tyre size		20.5R25 L3		20.5R25 L3	
Operating weight	kg	15,085	15,195	15,241	15,352

1) Measured to the tip of the bucket teeth

DIMENSIONS

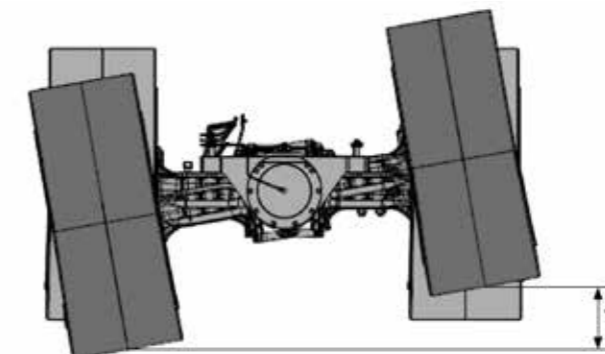
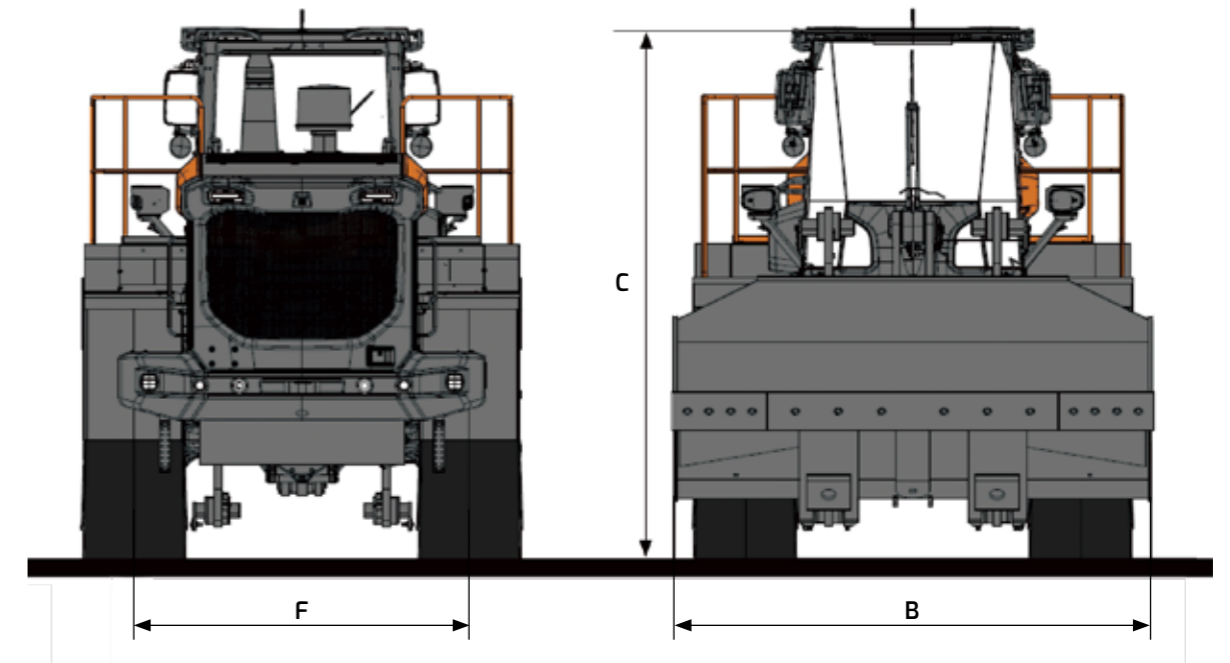
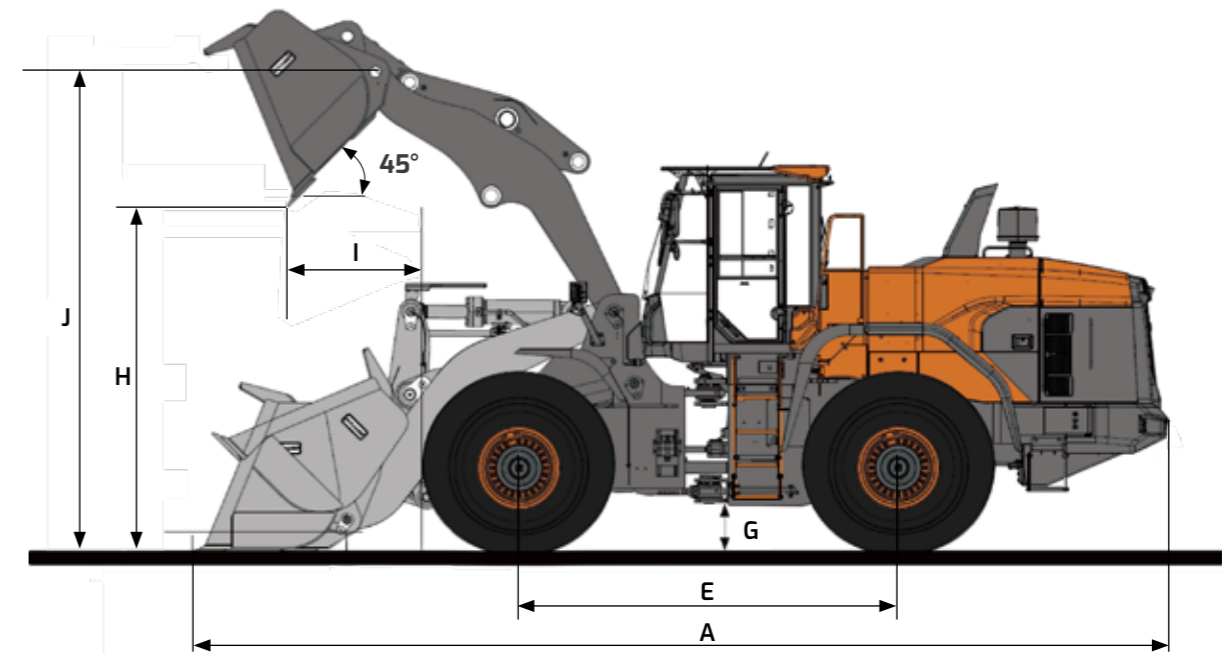

STANDARD & OPTION

STANDARD EQUIPMENT

Engine

- Develon DL06 engine
- Air cleaner - Double element cartridge + Cyclone filtration in prior stage
- Fuel filter - Main fuel filter and fuel pre-filter with water separator
- External drains for engine oil and coolant changes
- Hydraulic radiator fan

Hydraulic System

- Hydraulic control valve - 2 spool
- Hydraulic Oil - VG46 Normal Weather
- Hydraulic main pump - Triple tandem vane
- Hydraulic control levers
- Boom kick out - Automatic
- Bucket return to dig - Automatic
- Automatic reverse Fan

Cabin and Interior

- 12V power socket
- Double filtered air cab
- Air conditioner and heater with recirculation function
- Dual Cup holder
- USB Charging Port
- Tinted glasses
- Sunglass Case
- Floor mat
- AM/FM Radio + MP3(USB)
- Windshield washer front and rear
- Windshield wipers front and rear
- Cigarette lighter
- Multiple storage compartments
- Front Sun visor
- Glass antenna
- Seat - Mechanical suspension
- ROPS cabin - ISO 3471
- FOPS cabin - ISO 3449
- Adjustable steering column
- Rear view mirrors - Interior 1
- Rear view mirrors - Exterior 2

Electrical and lighting

- Battery cut-off switch
- Working light - Front 2 + Rear 2
- Driving light - Low and high beams
- Tail indicators - Stop, reversing lights
- Reversing alarm
- Electric horn
- Alternator - 24V, 80A
- Self-diagnostic system

Linkage

- Z-bar loader linkage

Drivetrain and Brake system

- Gear shift switch - Manual, Auto 1 4, Auto 2 4
- Kickdown and travelling direction selection
- Starting safety system
- Dual brake circuits with accumulator
- Secondary brake system
- Parking brake - Electrical, hydraulic
- Differential - Limited slip
- Thermostat

Steering system

- Load sensing steering system

External equipment

- Fender

OPTIONAL EQUIPMENT

Some of these optional equipments may be standard in some markets. Some of these optional equipments cannot be available on some markets. You must check with the local Develon dealer to know about the availability or to release the adaptation following the needs of the application.

Hydraulic System

- Hydraulic Oil - VG68 Tropical Weather
- Hydraulic control valve - 3 spool
- Load isolation system (LIS)
- Hydraulic control levers - Mono
- Hydraulic control levers - FNR
- Quick coupler port and switch

Cabin and Interior

- Seat - Air suspension with heater
- Camera - Rear view
- Rear Sun visor

Electrical and lighting

- License lamp
- Beacon - Rotating
- LED working lamp
- Heated side mirrors

Linkage

- Z-bar high lift loader linkage

Drivetrain and Brake system

- Dual service brake pedals

Steering system

- Emergency steering pump

External equipment

- Fender - Full fender + rubber protector
- Fender - Rubber protector
- Wheel chocks
- Anti-noise Kit
- Additional counterweight - 0.3 ton
- Tool Kit

* Standard specification and options may vary by country.

** Specification is subject to change without prior notice for quality enhancement.